

A system for animal eye research with profound flexibility

The Phoenix Ganzfeld ERG takes advantage of the Maxwellian view illumination technique to avoid the large size of the traditional bowl illumination approach. It is uniquely and specifically designed as a stand alone Ganzfeld for the rodent eye with the ability to test the function of retinal cells.

The unique Maxwellian view design enables placing the corneal electrode on the front lens.

With an infrared camera for guidance, the electrode can be gently contacted to the cornea even in the dark, keeping absolutely dark adaptation and stable contact with the eye.

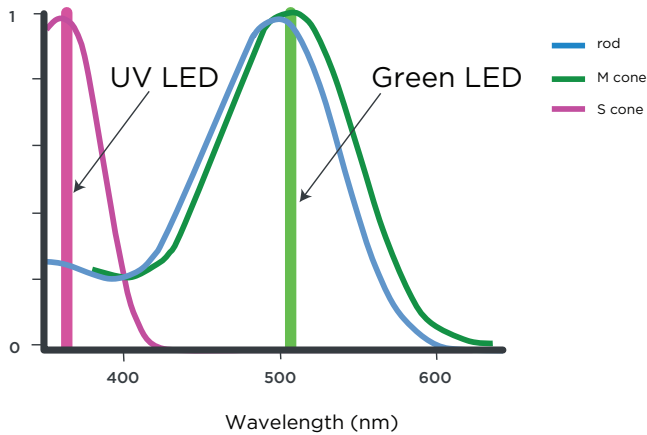
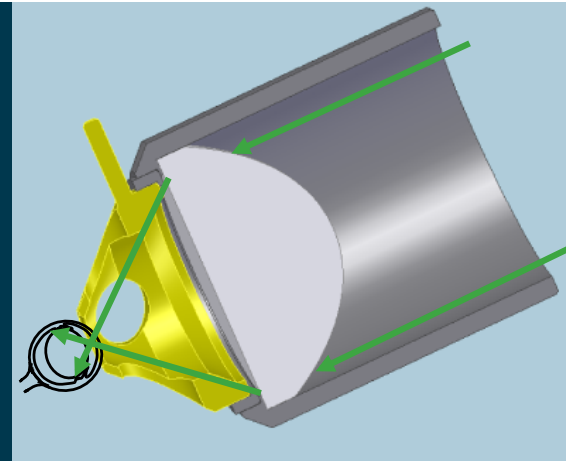
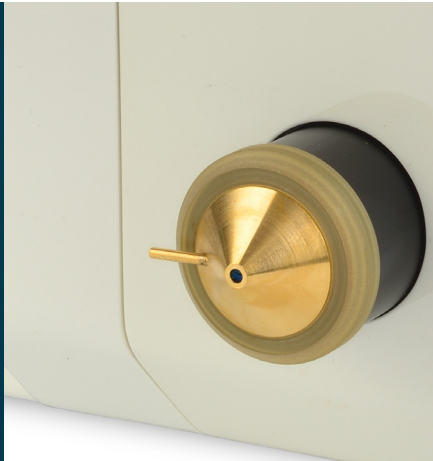

Measure responses:

The Phoenix Ganzfeld delivers both 505 nm and 365 nm to enable studies of both the cone and rod photoreceptors. The use of a single LED light source not only preserves bench space, but provides extraordinary flexibility in separately testing each of these photoreceptor classes. A near infrared (NIR) LED at 780 nm is used for pupil alignment. This is a wavelength where there is no response from the rodent retina, thereby maintaining the very best possible levels of scotopic adaptation.

Scotopic Threshold Response (left) to Early Receptor Potential (right)

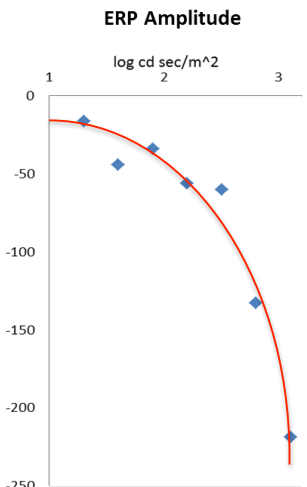
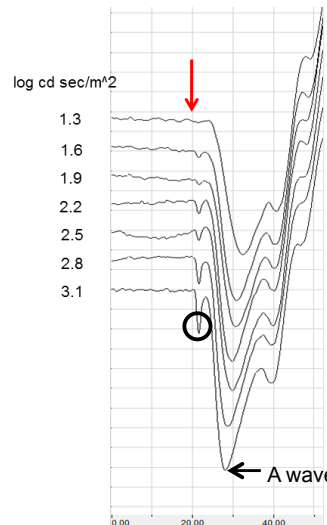
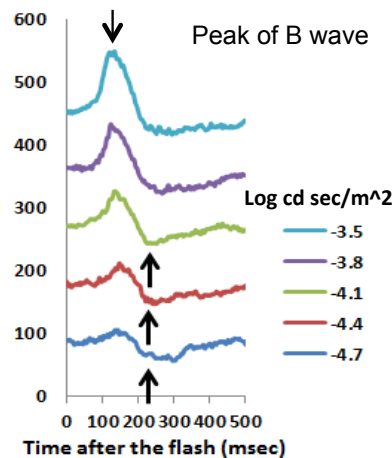

A wide variety of signal protocols is available through an intuitive interface

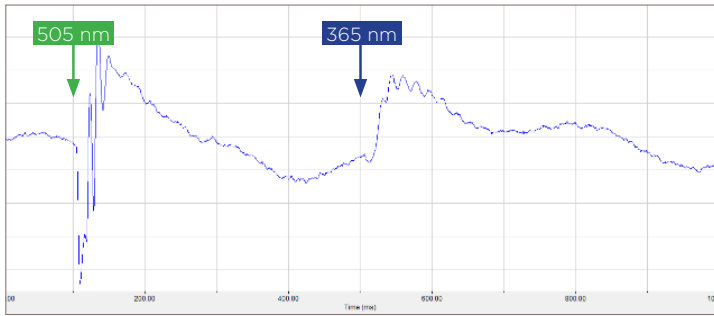

Double pulse, arbitrary wavelength selection

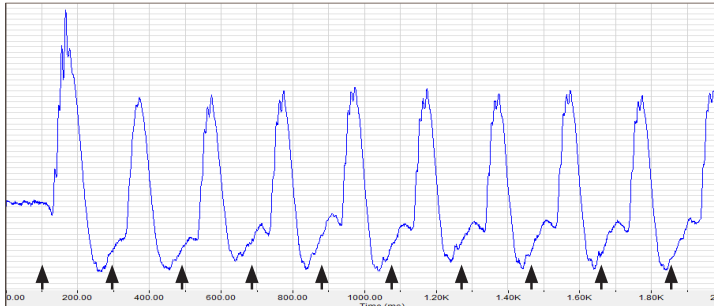

Flicker, arbitrary selection of frequency and background

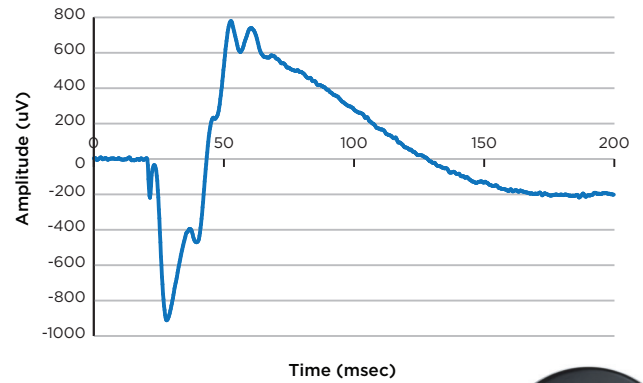

Maxwellian View Illumination

The Maxwellian view illumination technique focuses the light from a single LED onto the nodal point of the eye using a small F# lens diverging the light to illuminate the entire retina. This approach, with its compact size and use of LEDs, requires only 50 cm of lab bench space.



Ganzfeld ERG

Stimuli	365nm & 504nm	
Illumination size in diameter	Full field	
Range of stimulation in log cd sec/m ²	-4.7 to 3.1 Set levels over a range of 10 ⁸	
Modes	Single flash Double/Flicker flash Alternate two-color flash	Continuous background with flash Light adaptation Chart mode
Pulse length	0.2 millisecond to minutes	
Contact electrode	Single objective lens for mouse and rat	
Camera	NIR Camera to align pupil	
Heater	Maintain 37 degrees Celsius for Mouse and Rat	
Pupil Alignment	Pupil alignment at 780nm	
Software & Controls for Acquisition and Analysis	Acquisition: CLEAN* mode to remove 60/50 pickup noise Controllable Bandwidth Controllable digitization sampling rate Controllable scan and display time Controllable all parameters of LEDs (Delay, pulse length etc..)	Analysis: Automatic measurement of A and B wave peaks Automatic display of waterfalls Automatic measurement of OP peaks and implicit time Averaging with user selection Export data as CSV or text file
Animal stage	5 degrees of freedom	
Electrodes	Corneal contact (gold-plate objective lens) Platinum needles for Tail (ground) and head (reference)	